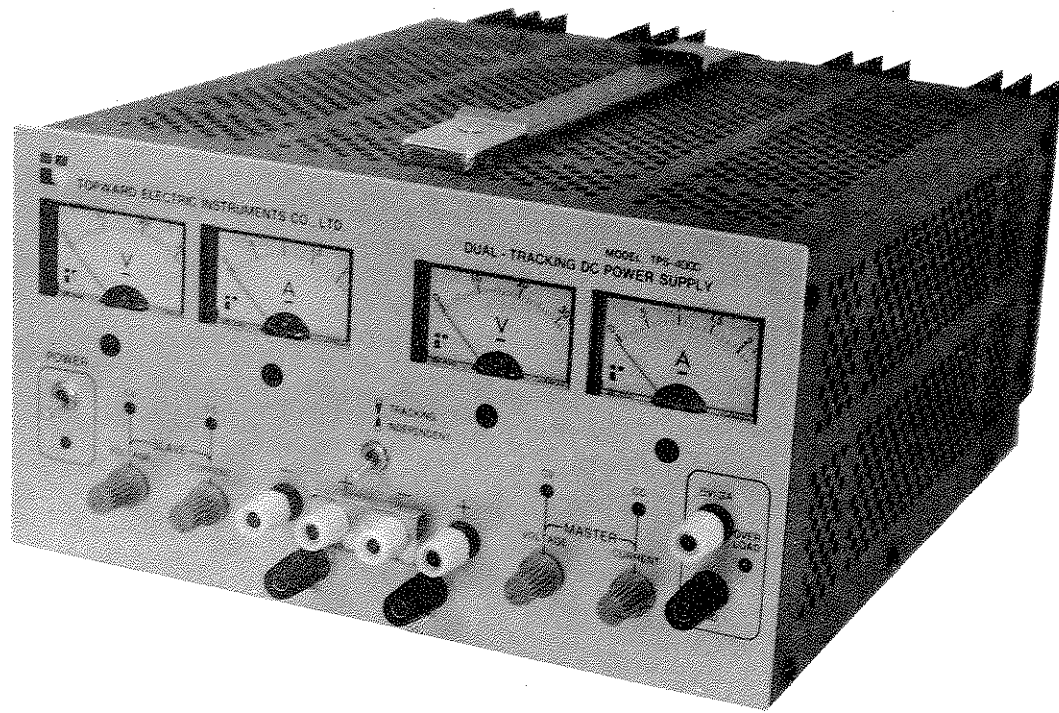

TABLE of CONTENTS

Picture of Model TPS-4000.....	1
Introduction.....	2
Before We Begin.....	2
Front Panel of Model TPS-4000 Series.....	3
Front Panel Description.....	4
Operating Instructions.....	5
Operating Cautions.....	5
Block Diagrams.....	6
Maintenance & Calibration.....	8
Troubleshooting.....	9
Circuit Diagrams	
Component Layout Diagrams	
Mechanical Assembly Drawings	
Specifications	
Parts list	

SpenceTek, Inc.
777 AMES AVENUE
MILPITAS, CA 95035
TEL (408)719-8868 FAX (408)719-8899
www.spencetek.com

PICTURE of MODEL TPS-4000



INTRODUCTION

The Topward Model TPS-4000 is a bench top triple output power supply. Voltage outputs may be electrically connected for tracking. The two main power supplies in the TPS-4000 have four meters for monitoring output voltage and current. Each of the power supplies is also equipped with independent controls for use when the unit is not being operated in the tracking mode. The remaining power supply has a fixed 5 volt 3 amp. output.

The TPS-4000 will find wide application in schools, laboratories, and commercial engineering and testing departments, as well as with the advanced hobbieist.

BEFORE WE BEGIN

The Topward Model TPS-4000 is packed in styrofoam to protect it during shipment from the factory. You should keep this material, as well as the shipping box, in case your unit must be moved or shipped again.

The box should include the following items:

- Model TPS-4000 Series power supply
- Removeable AC line cord
- Banana plug to Alligator clip cables
- Instruction manual

Please check to see that all of the above items are included.

FRONT PANEL of MODEL TPS-4000 Series

Figure - 1

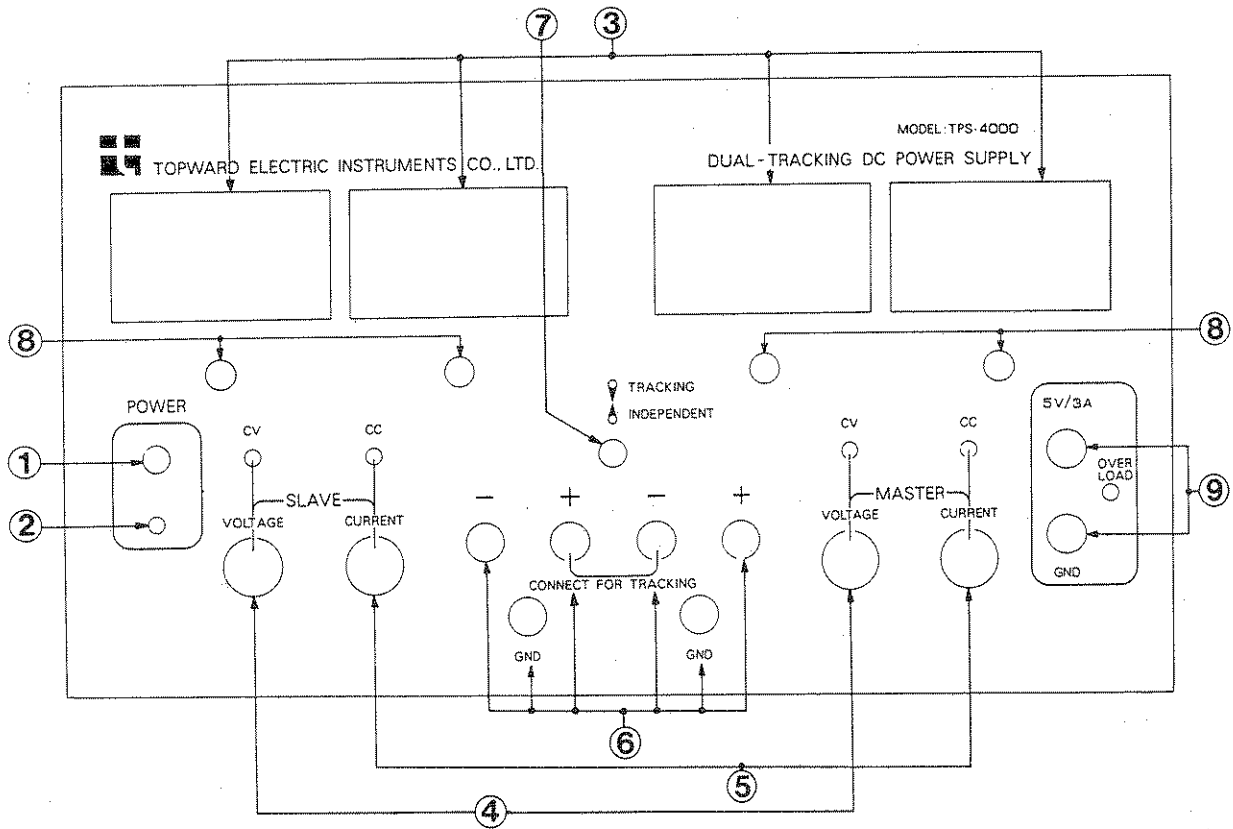

FRONT PANEL DESCRIPTION

The following is the explanation of the function of each of the front panel controls and connectors. You should refer to Figure 1 for the location of each control/connector.

1. POWER ON - This is the main power switch.
2. POWER ON LED - This LED indicates that the power is on.
3. VOLTAGE/CURRENT METERS - These four meters indicate the output voltage and current as measured at the output terminals.
4. VOLTAGE ADJUST - These two controls adjust the output voltage of the two supplies.
5. CURRENT ADJUST - These two controls adjust the output current that the two supplies will put out.
6. OUTPUT TERMINALS - There are two sets of three terminals (one set for each supply). They represent positive, negative and ground. Note that the two inside connectors (one + the other -) should be connected together when the supply is used in tracking mode.
7. INDEPENDENT/TRACKING SWITCH - This toggle switch is used to turn the tracking function on and off.
8. METER ZERO - Each meter has a mechanical screw adjustment for setting the zero point.
9. 5V/3A OUTPUT - These two terminals have a fixed 5V/3A voltage output. The GND terminal is connected to the earth ground. (Model 4302, 4303 only).

OPERATING INSTRUCTIONS

WARNING - Before applying power to your TPS-4000 Series power supply, make sure that the AC input voltage setting SW03 and SW04 on bottom (Models 4302, 4303) or on rear panel (Models 4306, 4603, 4602) is correctly set for your available power.

1. Connect the instrument to an AC power source using the line cord provided and turn the POWER ON switch (1) on. For maximum stability, allow the instrument to warm up for at least 20 minutes.
2. Independent Mode - Set the INDEPENDENT/TRACKING switch (7) to the independent position. The two sets of voltage and current adjustment knobs may then be used to set the outputs to the desired levels.
3. Tracking Mode - Set the INDEPENDENT/TRACKING switch (7) to the tracking position. Using the voltage adjustment knob marked "MASTER", set the desired output voltage. The slave channel will have the same output voltage (but opposite polarity) as the master. You may use the two current adjust knobs to independently set the maximum current for each channel.

OPERATING CAUTIONS

Please follow the following cautions when using your Model TPS-4000 Series power supply to prevent damage to the unit.

1. Verify that the AC voltage setting is the same as your available power BEFORE you apply power to the instrument.
2. Do not connect a voltage that is greater than the current output voltage to the terminals of the instrument.
3. Do not overload the 5 volt/3 amp output (Model 4302 and 4303 only) for more than 20 minutes in any one hour period.
4. Do not parallel the output of TPS-4000 series.

MAINTENANCE & CALIBRATION

To keep your TPS-4000 Series power supply in top working condition, you should periodically calibrate it. As you follow the adjustment procedure below, refer to the component layout diagram for the location of the adjustment components.

1. Mechanical zero adjustment - Using a small screwdriver, turn off the power and adjust the four screws under the meters to read zero.
2. Set the TRACKING/INDEPENDENT switch (7) to Independent.
3. Turn on the unit and connect a digital multimeter (Topward Model TDM-104 or equivalent) set to the 200 volt range to the output terminals. Turn the Voltage Adjustment knob (4) fully clockwise. Adjust R33 until the output is within the range 31V - 33V (Models 4302, 4303, 4306) or 62V-65V (Models 4602, 4603).
4. Turn the Voltage Adjustment knob (4) until the output voltage is exactly 30 volts (Models 4302, 4303, and 4306) or 60 volts (Models 4602 and 4603). Adjust R34 until the meter reads 30 volts or 60 volts depending on the model.
5. Set the multimeter to measure DC amperes and the range to 20A. Turn the Voltage Adjustment knob to approximately 25% of full scale and the Current Adjustment knob to maximum. Adjust R32 in order to have a minimum output current: 2.1A (Models 4302 and 4602), 3.1A (Models 4303, 4603) or 6.1A (Model 4306)
6. Turn the Current adjustment knob (5) until the output current is exactly 2 amps (Model 4302 or 4602), 3 amps (4303, or 4603) or 6 amps (Model 4306). Adjust R35 until the meter indicates the above values.

TROUBLESHOOTING

1. Control Section for Power Supply and Correct Reference Voltage (for both channel and independent modes)

- A. Check to be sure that voltage select switch on bottom (Model 4302, 4303) or on rear panel (Model 4306, 4602, 4603) is switched to correct line voltage.
- B. With power on, check CC, CV, and power LED. If there is indication of functional error, turn off power. Then check transformer and fuse on rear panel.
- C. Turn on power again and consult circuit diagram. There are two diode bridge circuits. The upper one from D01 to D04 is for the main power source. The lower one from D05 to D08 is for the control circuit and the reference voltage generator.
- D. Check to be sure that the Q05 emitter is set at a positive reading of $9.6V \pm 10\%$ and that the Q06 emitter is set at a negative reading of $11.5V \pm 10\%$. The DMM GND (negative) clip must be clipped to the main output (positive) terminal.
- E. Check CR03 to be sure that CR03 shows a positive reading of $3.3V \pm 10\%$ and that CR04 shows a negative reading of $8.2V \pm 10\%$.

2. Voltage Control Circuit

- A. Turn the voltage vernier to minimum and the current vernier to maximum. Check to be certain that the U03 pin 6 shows a reading of from $-5V$ to $-12V$.
- B. Then turn the voltage vernier to maximum and check to see that U03 pin 6 shows a reading of $+2V \pm 20\%$.
- C. Please note that the positive voltage control current passes through Q01, Q02, and Q07.
- D. The voltage meter is controlled by the voltage vernier.

3. Current Control Circuit

- A. Turn the current vernier to minimum. Check to be sure that the U02 output shows a reading of from -5V to -9V.
- B. Turn voltage vernier to maximum.
- C. Connect the positive output terminal and the negative output terminal with a 5 Ohm 50W resistor or similar component.
- D. The current meter is controlled by the current vernier.

4. Relay Circuit and the CC and CV LED

- A. The U01 relay control IC is controlled by the output voltage. At approximately half of maximum output the relay will change state. Please note that with specially ordered power supplies there may be a four state relay change.
- B. The CC LED is controlled by the constant current mode. Otherwise it will be controlled by the constant voltage mode.

5. Tracking

- A. Turn the tracking switch to tracking location.
- B. The slave IC U03 is controlled by the master output which is positive. Its output passes through slave transistor Q01, Q02, and Q07 to the positive slave output.

A

B

C

D

E

REVISION	DATE

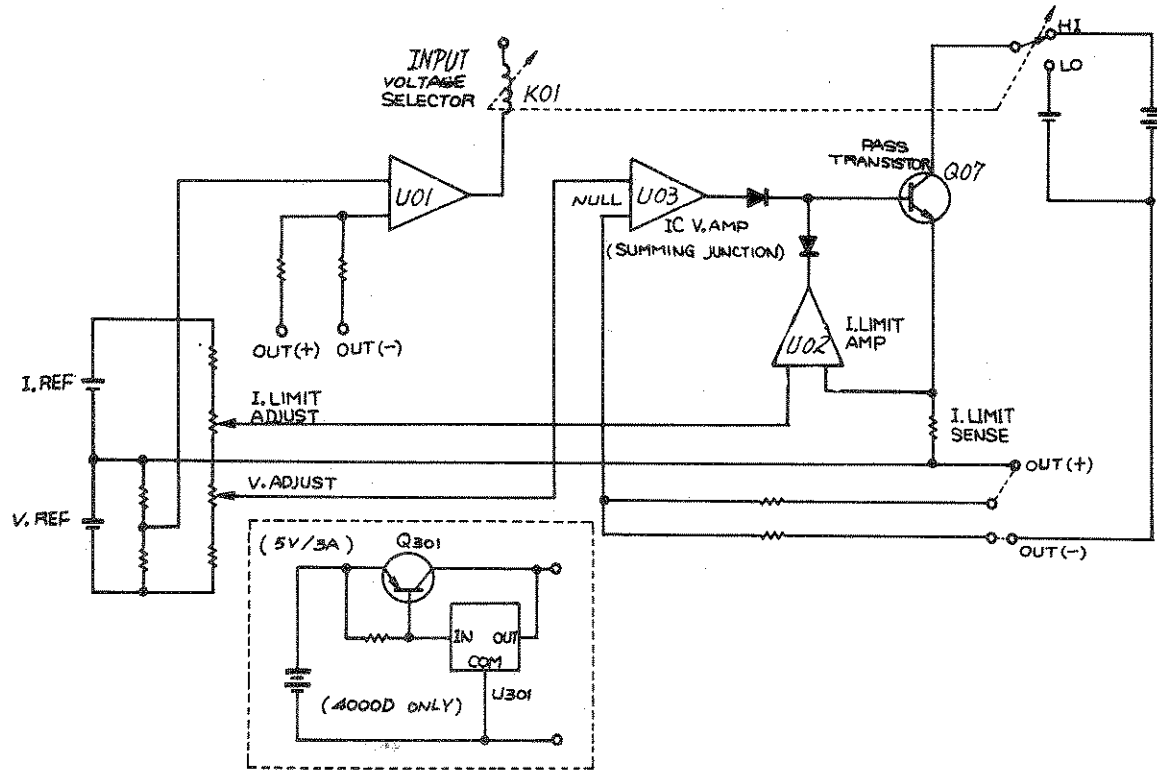

DO NOT SCALE THIS DRAWING	TOLERANCE UNLESS SPECIFIER ARE	4000 SERIES BLOCK DIAGRAM
	ANGLES ± DECIMALS ±	
 TOPWARD ELECTRIC INSTRUMENTS CO., LTD.	DRAWER <i>B. Q. Huang</i>	DRAWING NO:
	DESIGNER <i>Simon Wang</i>	APPROVED <i>Simon Wang</i>

A

B

C

D

E

REVISION	DATE

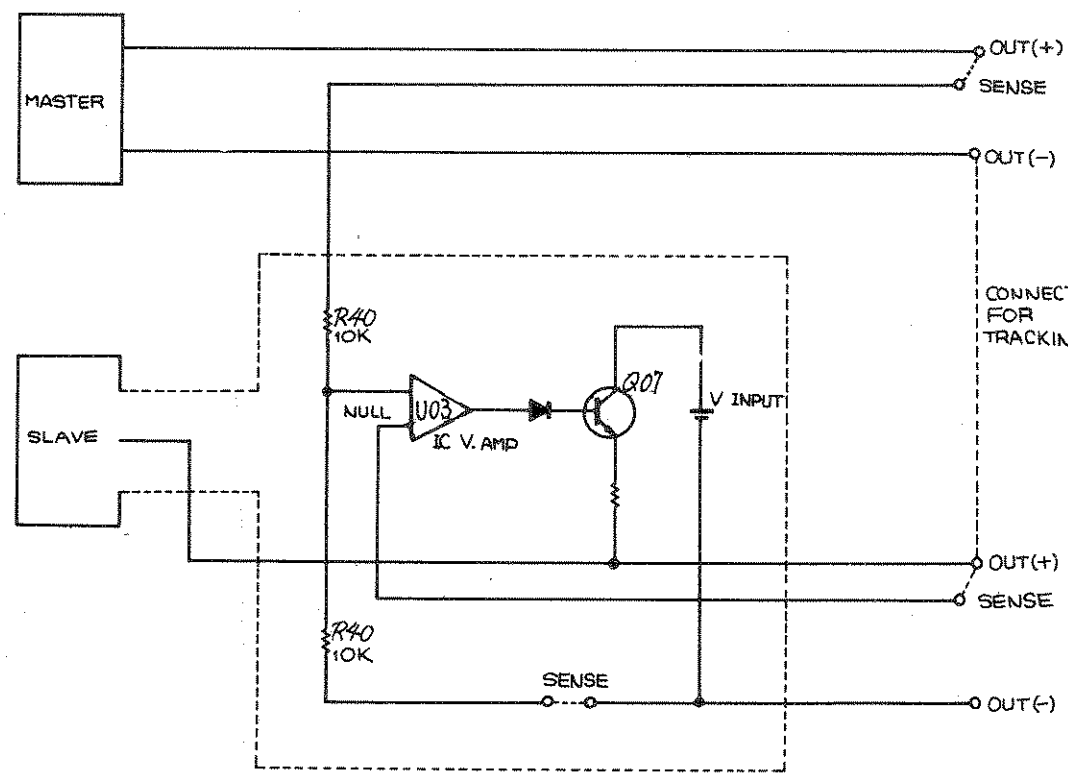

DO NOT SCALE THIS DRAWING	TOLERANCE	4000 TRACKING MODE	
	UNLESS SPECIFIER ARE	BLOCK DIAGRAM	
 TOPWARD ELECTRIC INSTRUMENTS CO., LTD.	ANGLES ±	DRAWING NO:	
	DECIMALS ±	DRAFTER <i>B. L. Hoang</i>	DESIGNER <i>Simon Wang</i>
		APPROVED <i>Simon Wang</i>	

NOTES

1. ALL RESISTOR VALUES ARE IN OHMS UNLESS OTHERWISE SPECIFIED.
2. ALL CAPACITOR VALUES ARE IN MICROFARADS UNLESS OTHERWISE SPECIFIED.

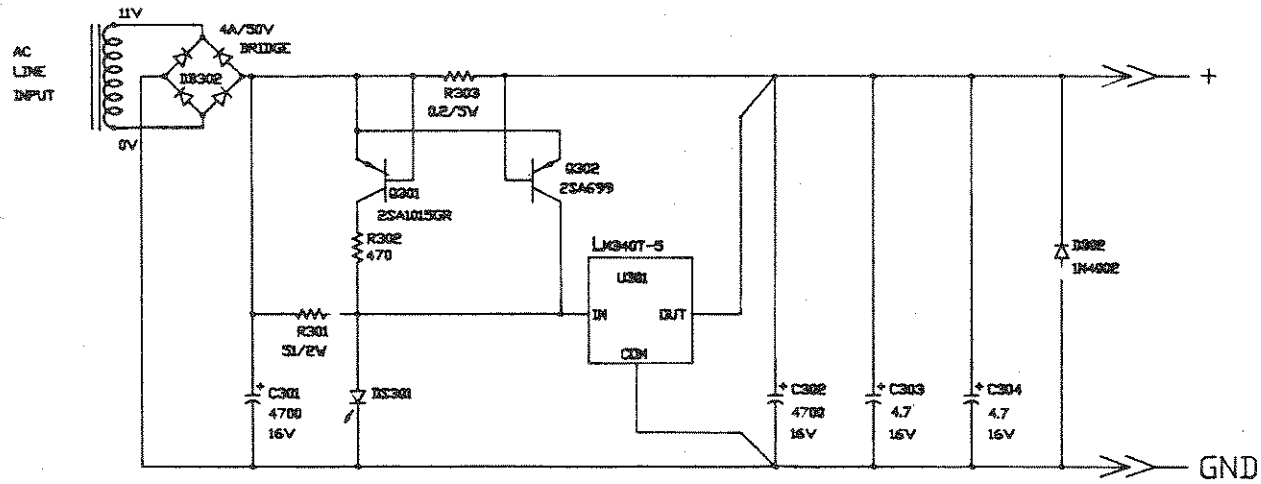

DWG No.		82002001	
DESCRIPTION		POWER SUPPLY 5V/3A CIRCUIT DIAGRAM	
DRAFTED BY	ANITA YUEN	4/6/1988	FIRST USED
DESIGNED BY			4303
APPROVED BY			SHEET SIZE
			1 of 1 A4

A

B

C

D

E

REVISION	DATE

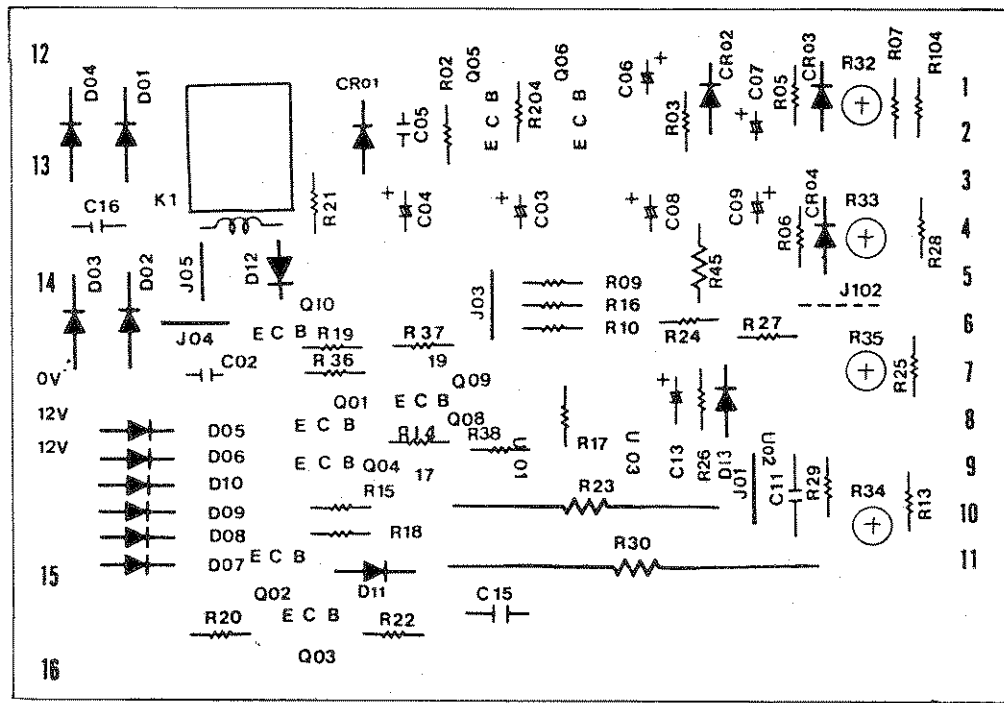

CURRENT ADJ.

VOLTAGE ADJ.

CURRENT METER ADJ.

VOLTAGE METER ADJ.

DO NOT SCALE THIS DRAWING	TOLERANCE UNLESS SPECIFIER ARE	POWER SUPPLY LOW POWER SERIES	
 TOPWARD ELECTRIC INSTRUMENTS CO., LTD.	ANGLES ±	COMPONENT LAYOUT	
	DECIMALS ±	DRAWING NO: 82400001	
DRAFTER	DESIGNER	APPROVED	

A

B

C

D

E

A B C D E

REVISION	DATE

1 2 3 4

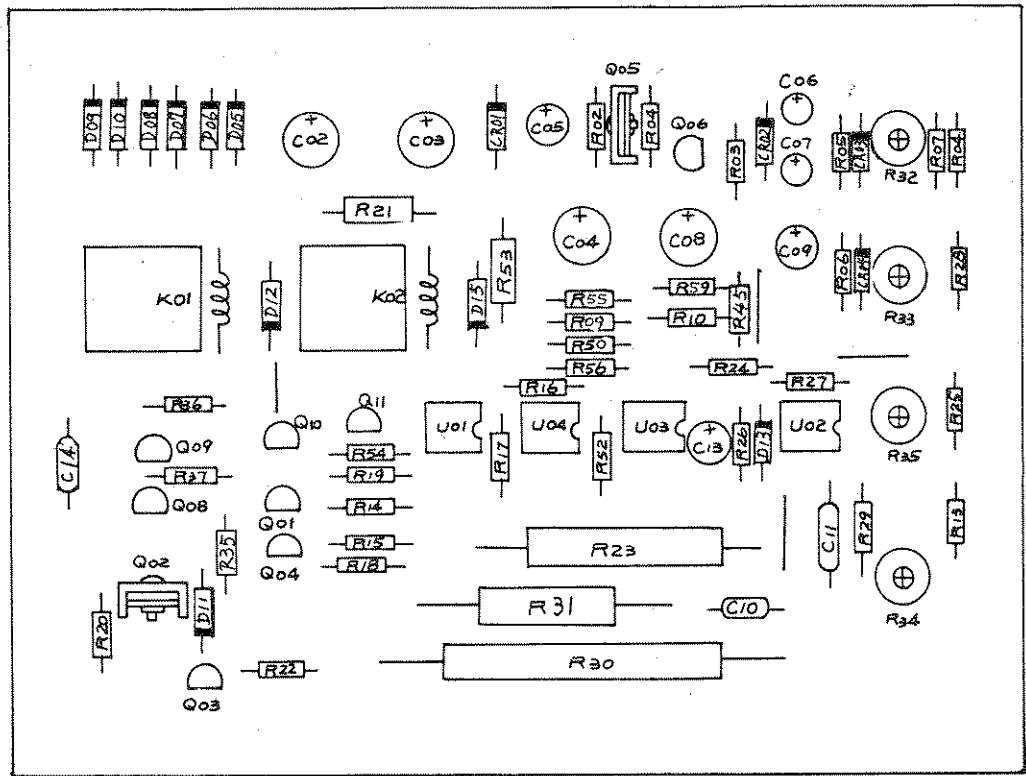

CURRENT ADJ.
 VOLTAGE ADJ.
 CURRENT METER ADJ.
 VOLTAGE METER ADJ.

3 4

DO NOT SCALE THIS DRAWING	TOLERANCE UNLESS SPECIFIER ARE	HIGH POWER DUAL RELAY COMPONENT LAYOUT	
 TOPWARD ELECTRIC INSTRUMENTS CO., LTD.	ANGLES ±	DRAWING NO: 82400002	
	DECIMALS ±	DESIGNER	APPROVED
	DRAFTER		

A B C D E

4

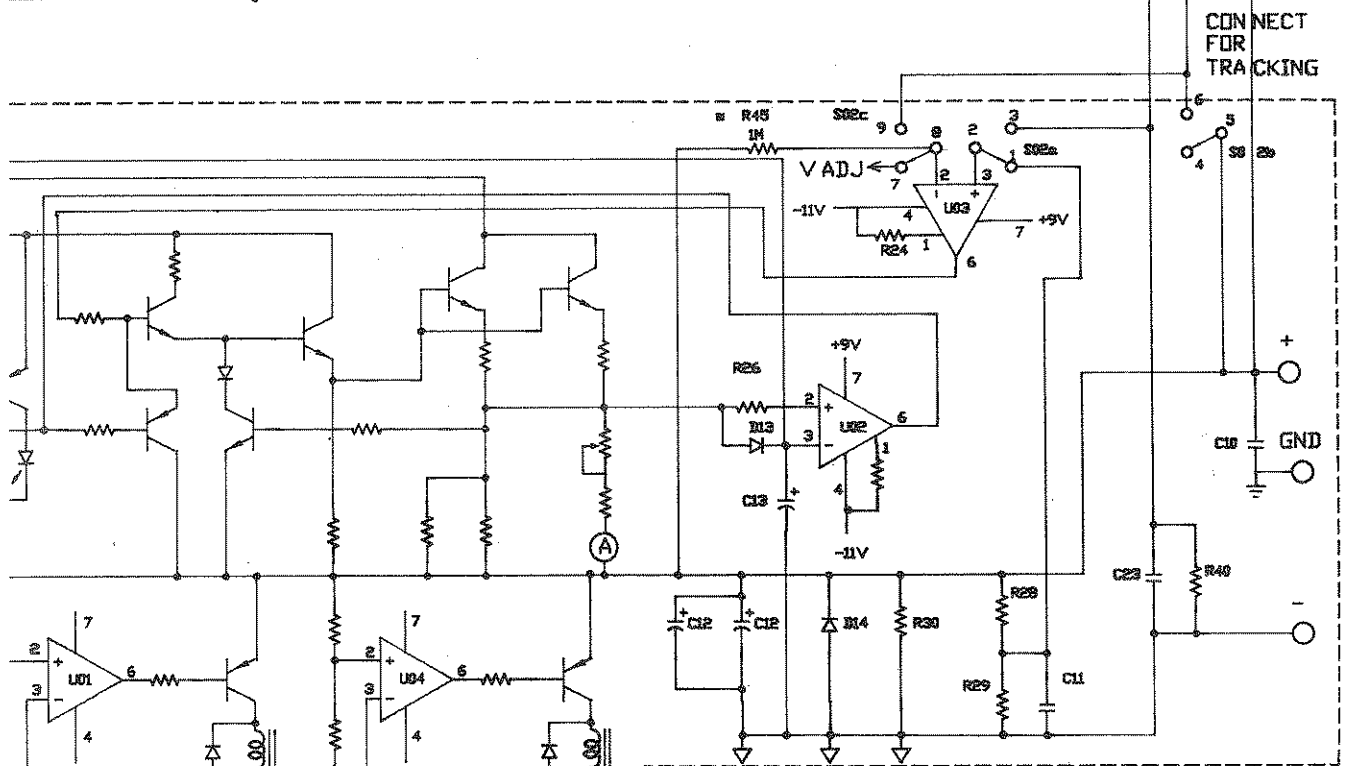
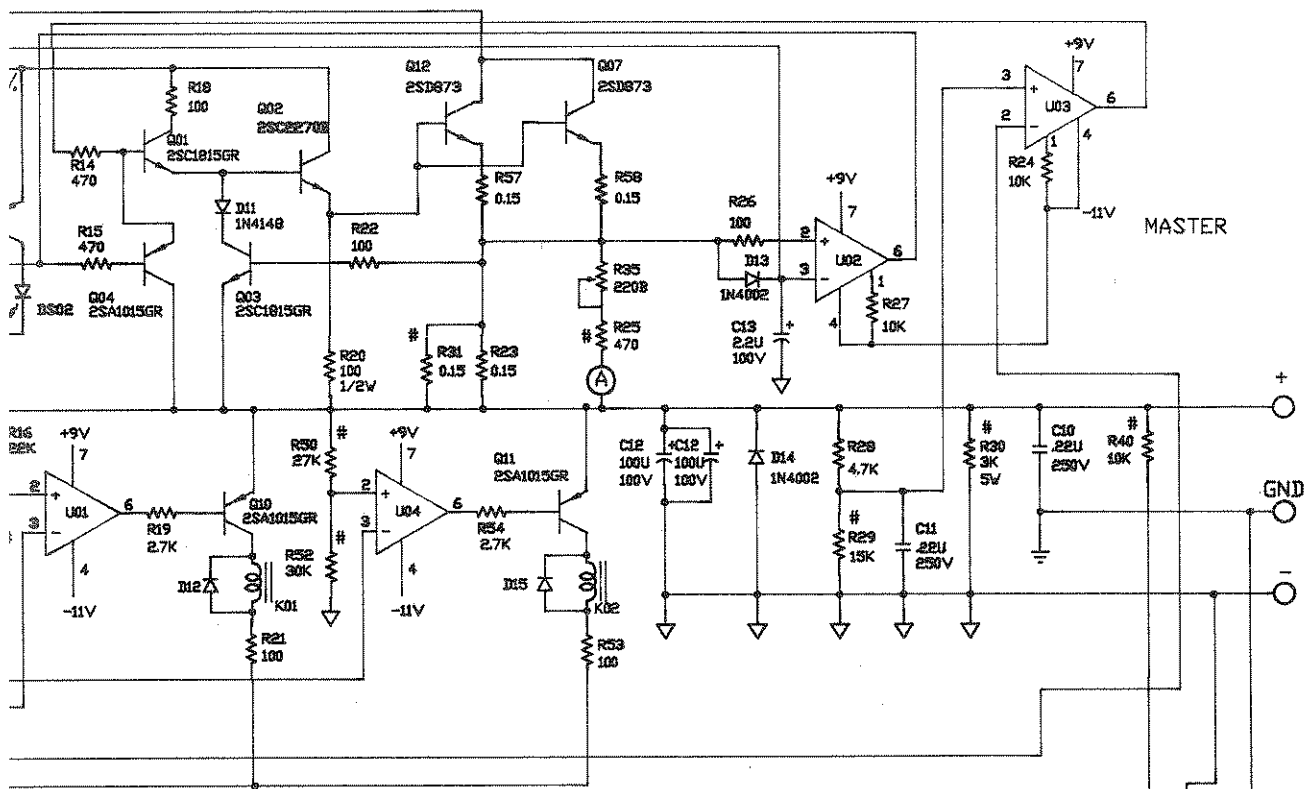

DWG No. 82002002		FIRST USED	
DESCRIPTION		TPS-4306	
DRAFTED BY	ANITA YUEN	4/13/1988	SHEET
DESIGNED BY			SIZE
APPROVED BY			_OF_ A3

110V 120V 220V 240V

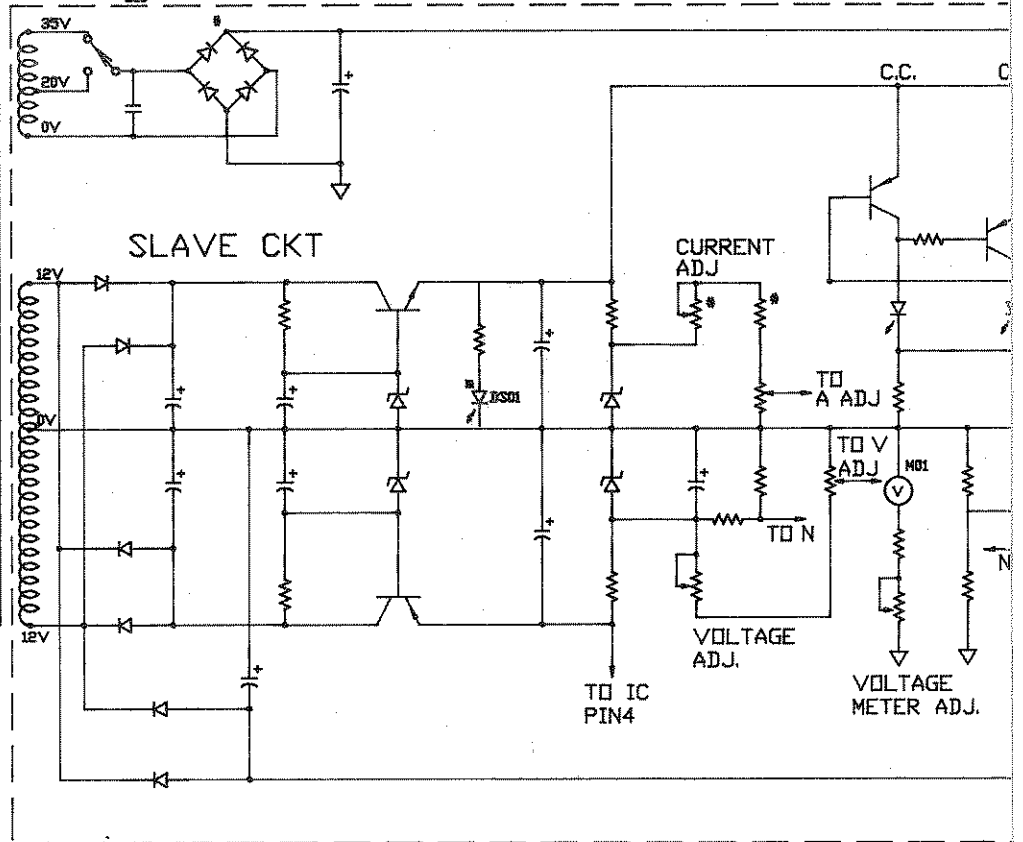
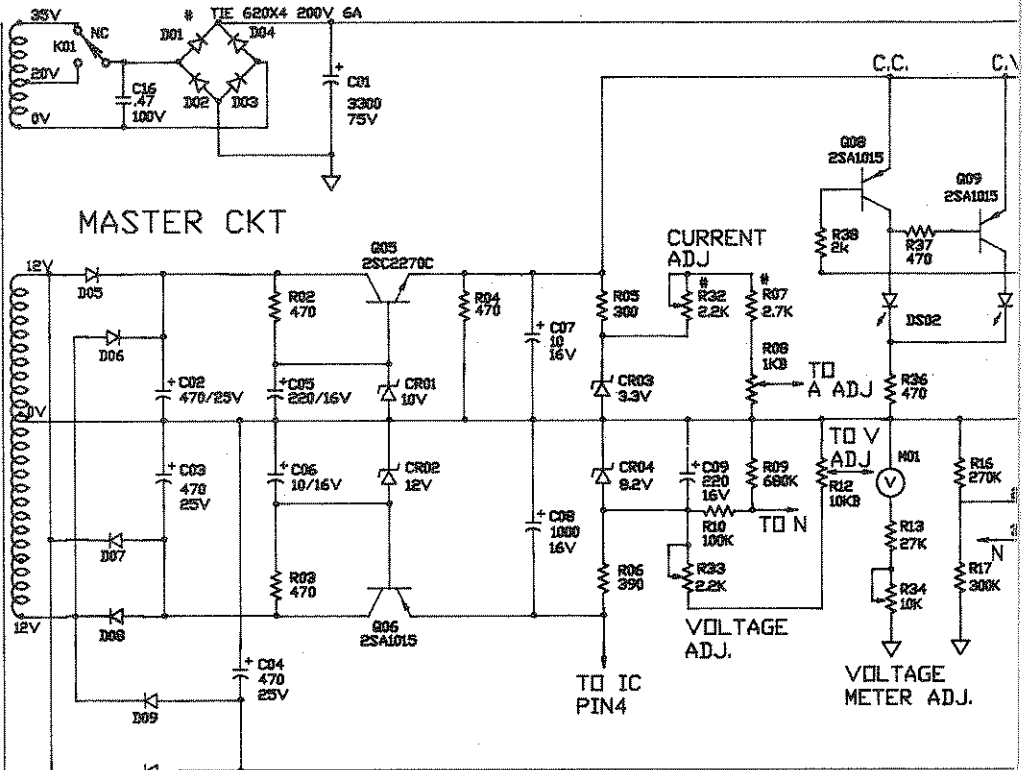
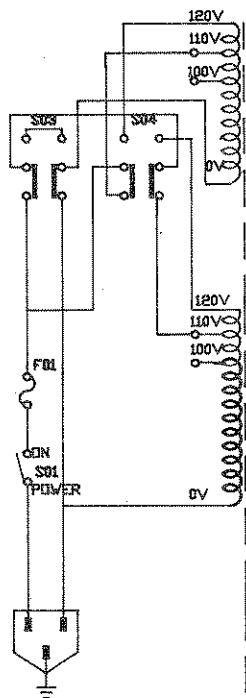

E	F	G	H
REVISION			DATE

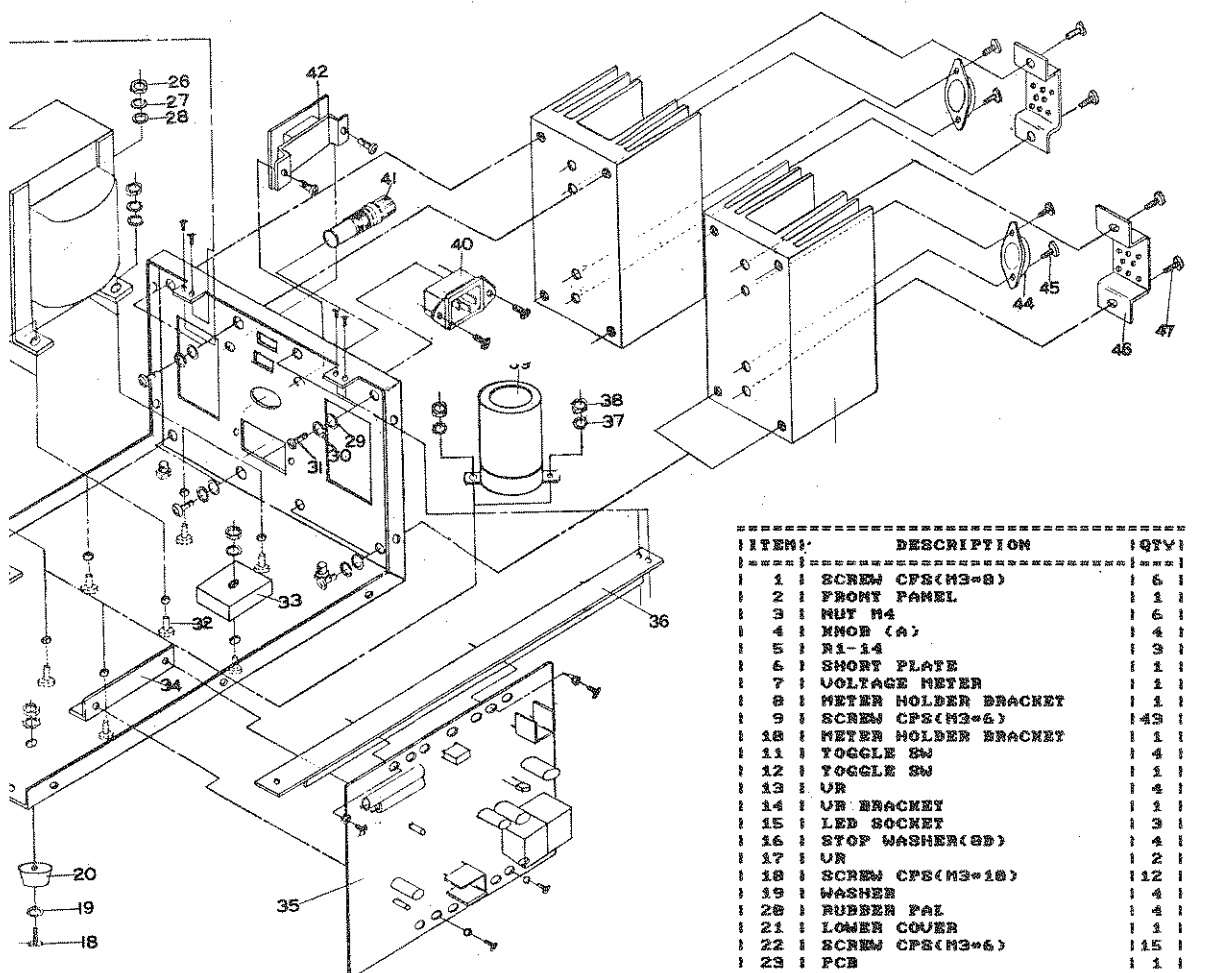

ITEM#	DESCRIPTION	QTY
1	SCREW CFS(M3=8)	6
2	FRONT PANEL	1
3	NUT M4	6
4	KNOR (A)	4
5	R1-14	3
6	SHORT PLATE	1
7	VOLTAGE METER	1
8	METER HOLDER BRACKET	1
9	SCREW CFS(M3=6)	4
10	METER HOLDER BRACKET	1
11	TOGGLE SW	4
12	TOGGLE SW	1
13	UR BRACKET	4
14	UR BRACKET	1
15	LED SOCKET	3
16	STOP WASHER(2D)	4
17	UR	2
18	SCREW CFS(M3=18)	12
19	WASHER	4
20	RUBBER PAL	4
21	LOWER COVER	1
22	SCREW CFS(M3=6)	15
23	PCB	1
24	PCB HOLDER BRACKET(R)	1
25	TRANSFORMER	1
26	NUT M4	6
27	SPRING WASHER	8
28	WASHER(4D)	6
29	WASHER(6D)	4
30	SPRING WASHER	6
31	SCREW CFS(M3=8)	6
32	SCREW CFS(M4=12)	4
33	DIODE BRIDGE	1
34	PCB HOLDER BRACKET(B)	2
35	PCB	1
36	PCB HOLDER BRACKET(L)	1
37	STOP WASHER(3D)	12
38	NUT(M3)	18
39	ELECTROLYTIC CAPACITOR	1
40	AC SOCKET	1
41	SLIDE SW	1
42	HEAT SINK	2
43	TRANSISTOR	2
44	SCREW CFS(M3=18)	12
45	TRANSISTOR COVER	2
46	SCREW CFS(M4=6)	4

DO NOT SCALE THIS DRAWING	TOLERANCE UNLESS SPECIFIER ARE	HIGH POWER DUAL RELAY	
 TOPWARD ELECTRIC INSTRUMENTS CO., LTD.	ANGLES ±	ASSEMBLY DRAWING	
	DECIMALS ±	DRAWING NO: 82502001	
DRAFTER: [Signature]	DESIGNER	APPROVED: [Signature]	

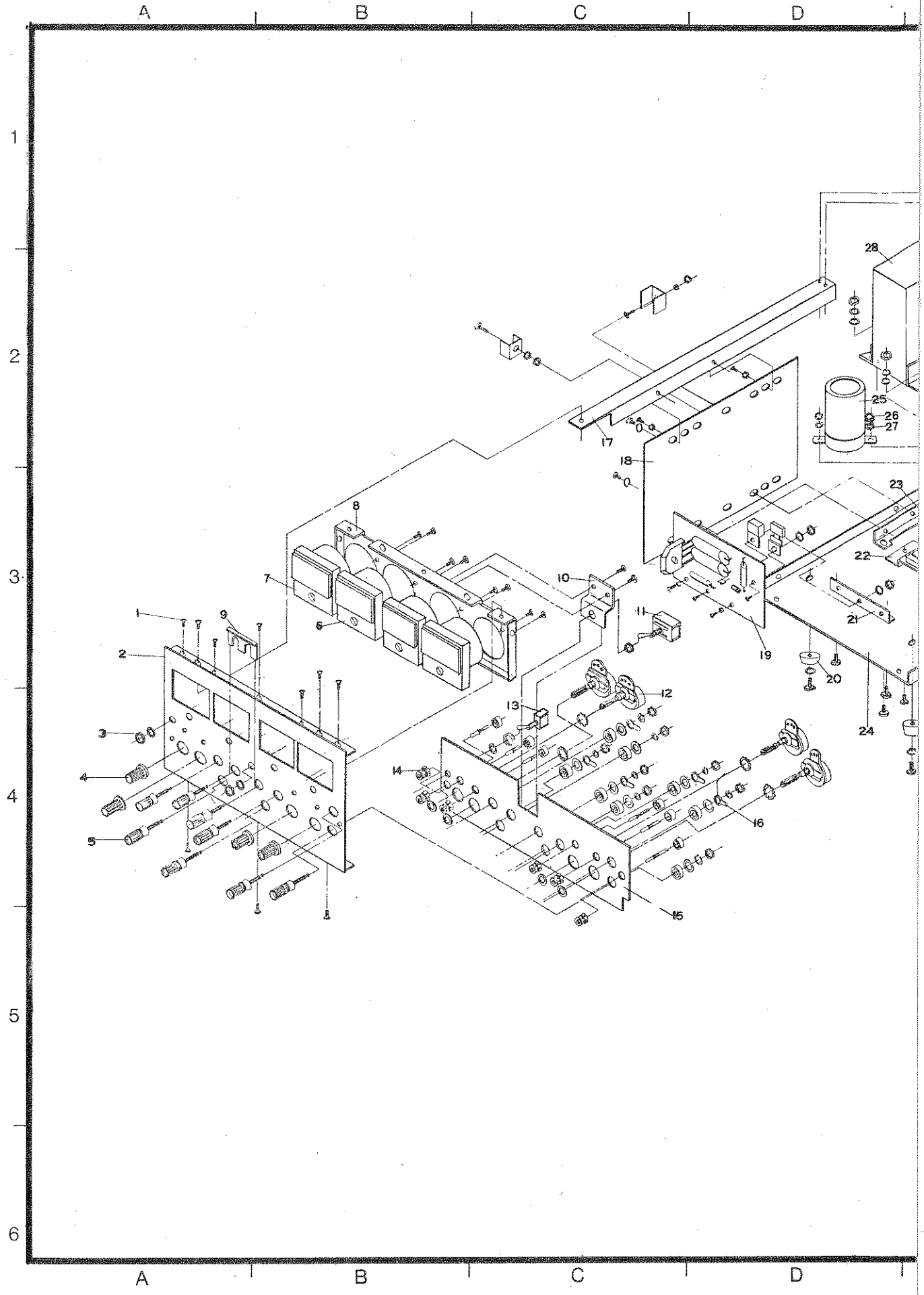

E

F



G

H

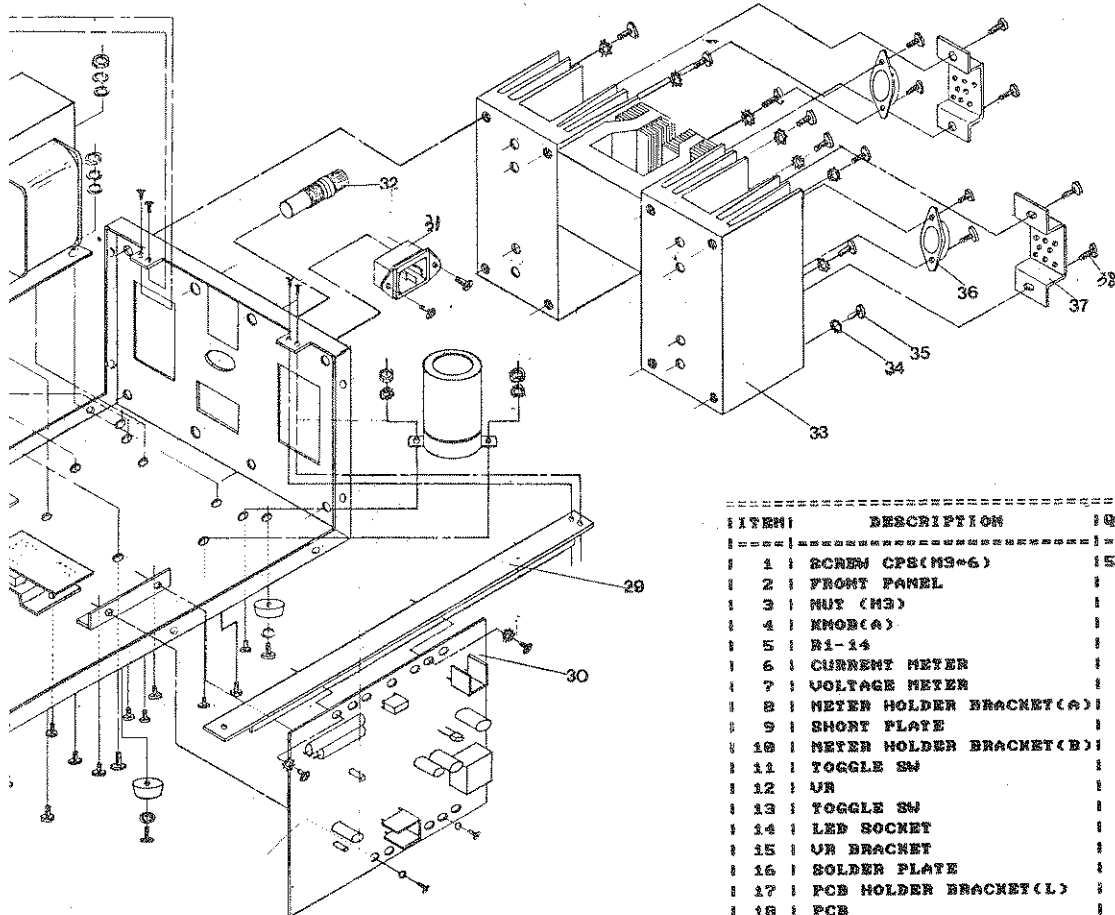
REVISION	DATE

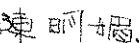

ITEM#	DESCRIPTION	QTY
1	SCREW CPS(M3*6)	150
2	FRONT PANEL	1
3	NUT (M3)	9
4	NMOB(A)	4
5	R1-14	7
6	CURRENT METER	1
7	VOLTAGE METER	1
8	METER HOLDER BRACKET(A)	1
9	SHORT PLATE	1
10	METER HOLDER BRACKET(B)	1
11	TOGGLE SW	1
12	UR	4
13	TOGGLE SW	1
14	LED SOCKET	1
15	UR BRACKET	1
16	SOLDER PLATE	5
17	PCB HOLDER BRACKET(L)	1
18	PCB	1
19	PCB	1
20	RUBBER PAD	4
21	PCB HOLDER BRACKET	3
22	SLIDE SW BRACKET	1
23	PCB HOLDER BRACKET	3
24	LOWER COVER	1
25	ELECTROLYTIC CAPACITOR	1
26	NUT(M3)	19
27	STOP WASHER(3D)	133
28	TRANSFORMER	1
29	PCB HOLDER BRACKET(R)	1
30	PCB	1
31	AC SOCKET	1
32	FUSE SOCKET	1
33	HEAT SINK	2
34	STOP WASHER	8
35	SCREW CRS(M3*14)	6
36	TRANSISTOR	1
37	TRANSISTOR COVER	1
38	SCREW CPS(M3*6)	4

DO NOT SCALE THIS DRAWING	TOLERANCE UNLESS SPECIFIER ARE	POWER SUPPLY LOW POWER SERIES	
	ANGLES ± DECIMALS ±	ASSEMBLY DRAWING	
 TOPWARD ELECTRIC INSTRUMENTS CO., LTD.	DRAFTER 	DRAWING NO: 82502000	
		DESIGNER	APPROVED 

E

F

G

H

1421-71

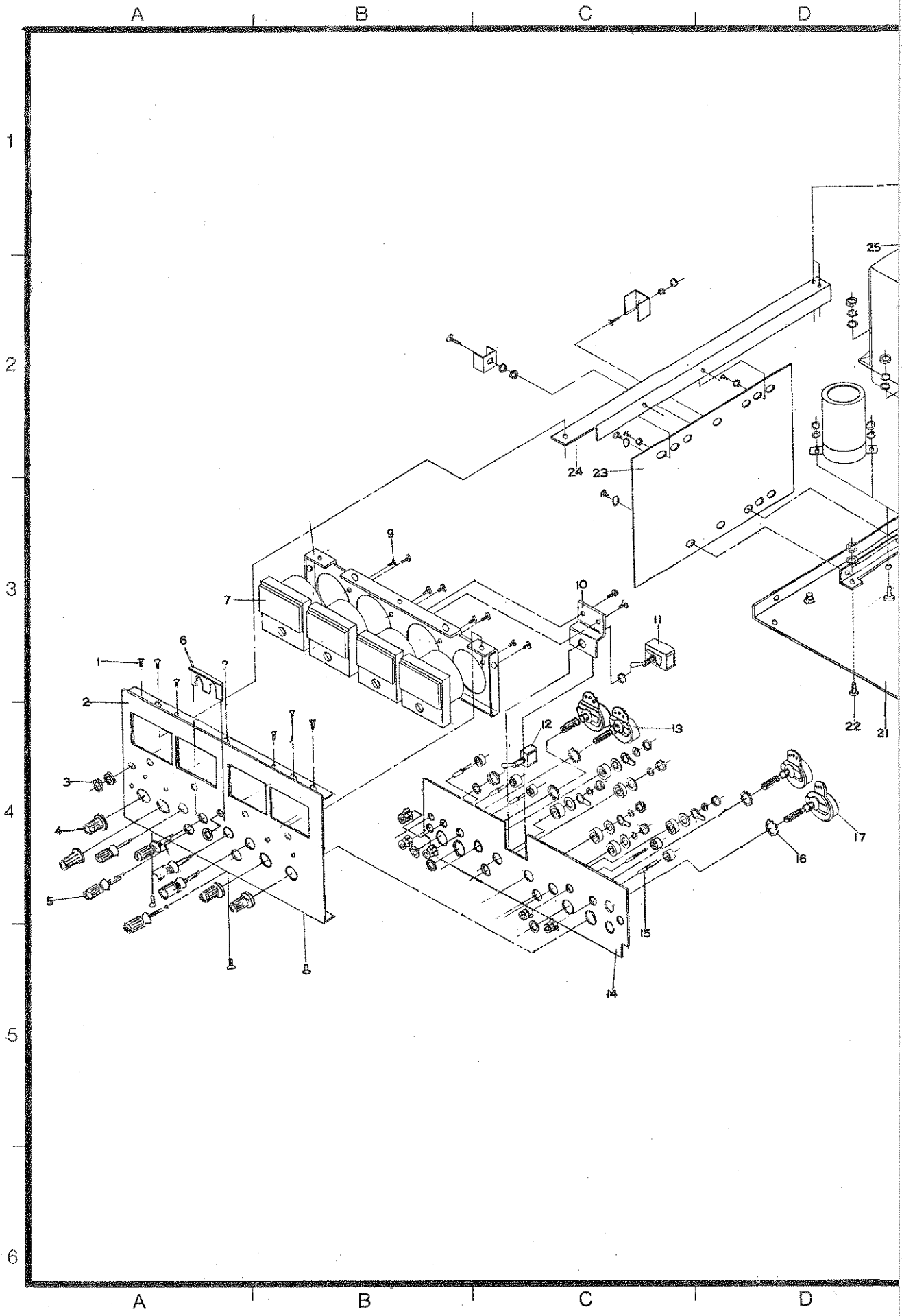

NOTES:

1. ALL RESISTOR VALUES ARE IN OHMS UNLESS OTHERWISE SPECIFIED. (K-KILOHM, M-MEGAOHM)
2. ALL CAPACITOR VALUES ARE IN MICROFARADYS.
3. ALL VALUES OF MASTER AND SLAVE ARE THE SAME UNLESS OTHERWISE SPECIFIED.
4. ALL VALUES OF TPS-4302 AND TPS-4303 ARE THE SAME UNLESS OTHERWISE SPECIFIED.
5. ↓ DENOTE OUTPUT-

6. * DENOTE VALUES WHICH MASTER AND SLAVE ARE DIFFERENT.

7. # DENOTE VALUES WHICH TPS-4302 AND TPS-4303 ARE DIFFERENT.

8. THE FOLLOWING TABLE SPECIFIES THE DIFFERENCE BETWEEN TPS-4302 AND TPS-4303

PART	4302		4303	
	MASTER	SLAVE	MASTER	SLAVE
R07	5.1k	5.1k	2.7K	2.7K
R25	270	270	330	330
R32	3.3k	3.3k	2.2K	2.2K
R45	NO	1M	NO	1M
DS01	NO	LED	NO	LED
D01-04	1N5402	1N5402	TIE 620	TIE 620
G07	2N3055	2N3055	2N3772	2N3772

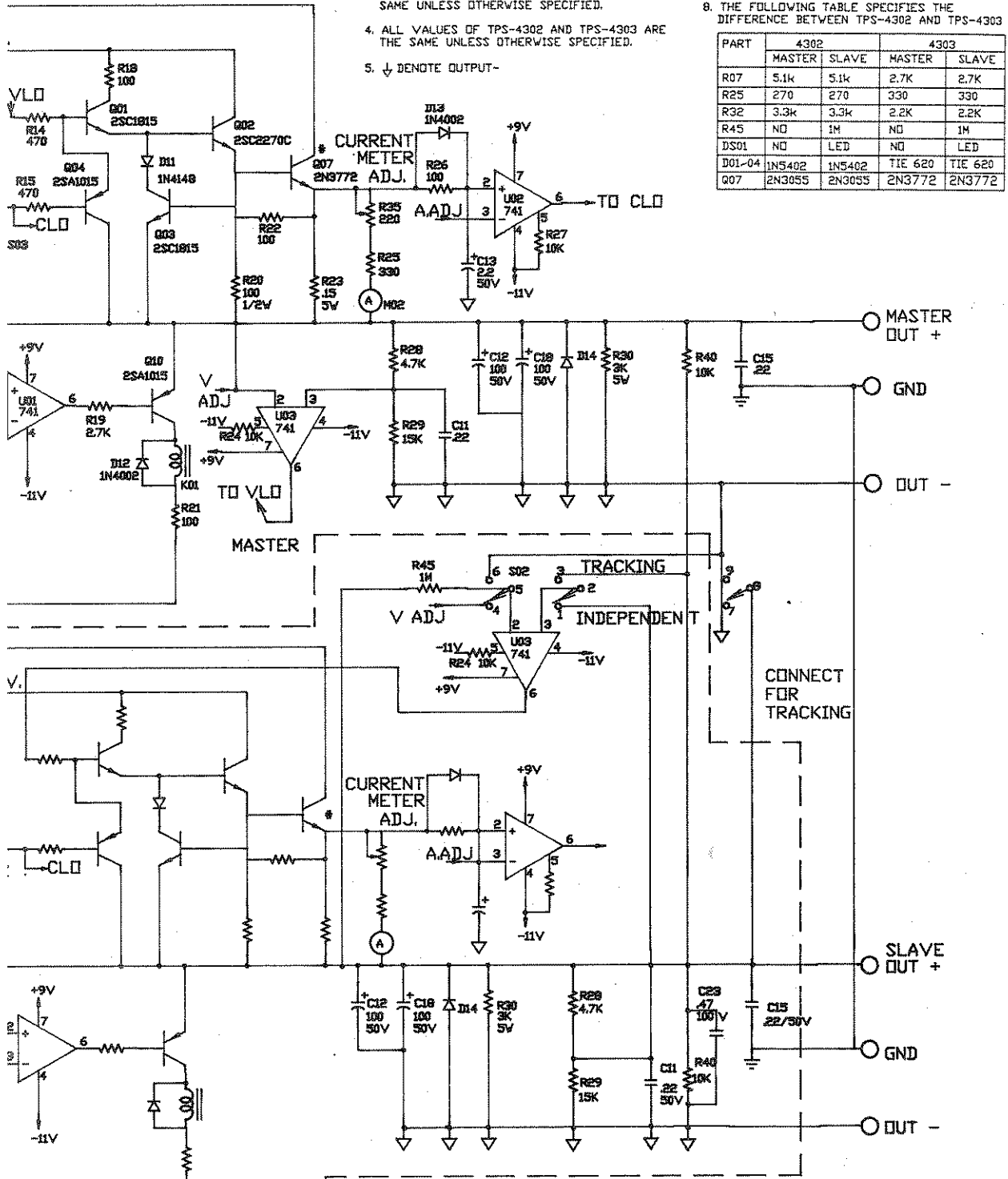

DWG No.	82002000		
DESCRIPTION	POWER SUPPLY LOW POWER SERIES CIRCUIT DIAGRAM		
DRAFTED BY	ANITA YUEN	3/15/1988	FIRST USED
DESIGNED BY			TPS-4303
APPROVED BY			SHEET SIZE
			__DF__ A3

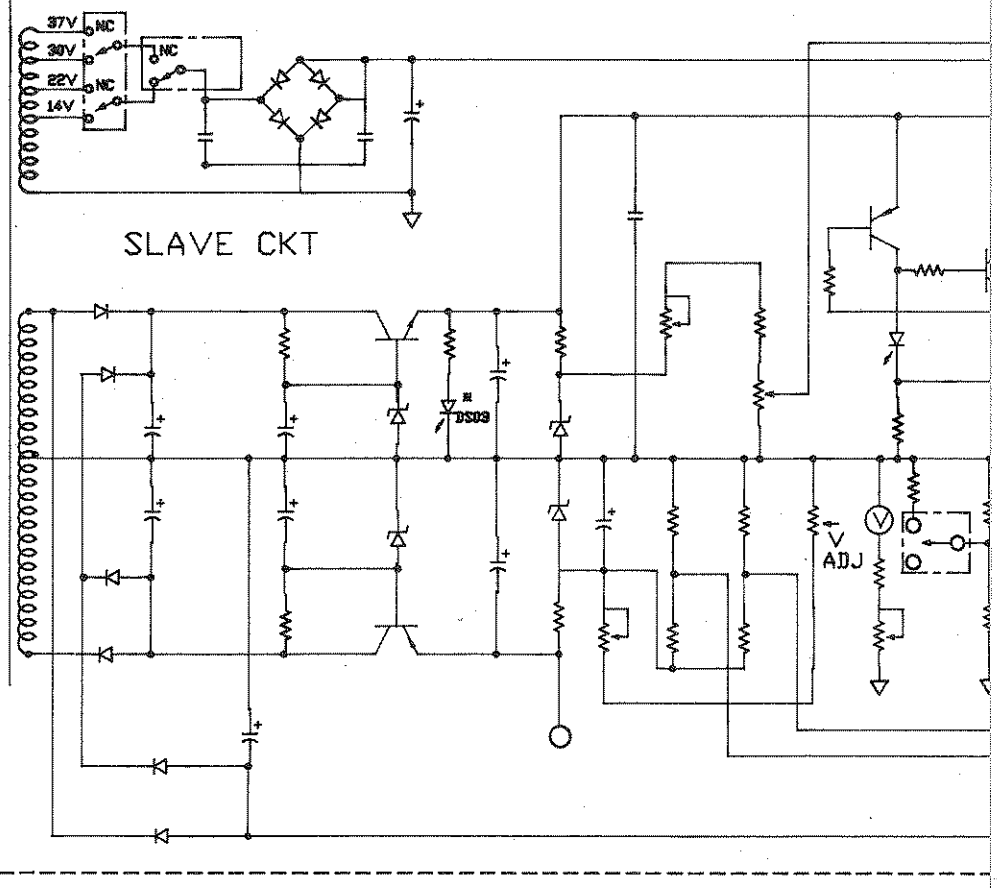
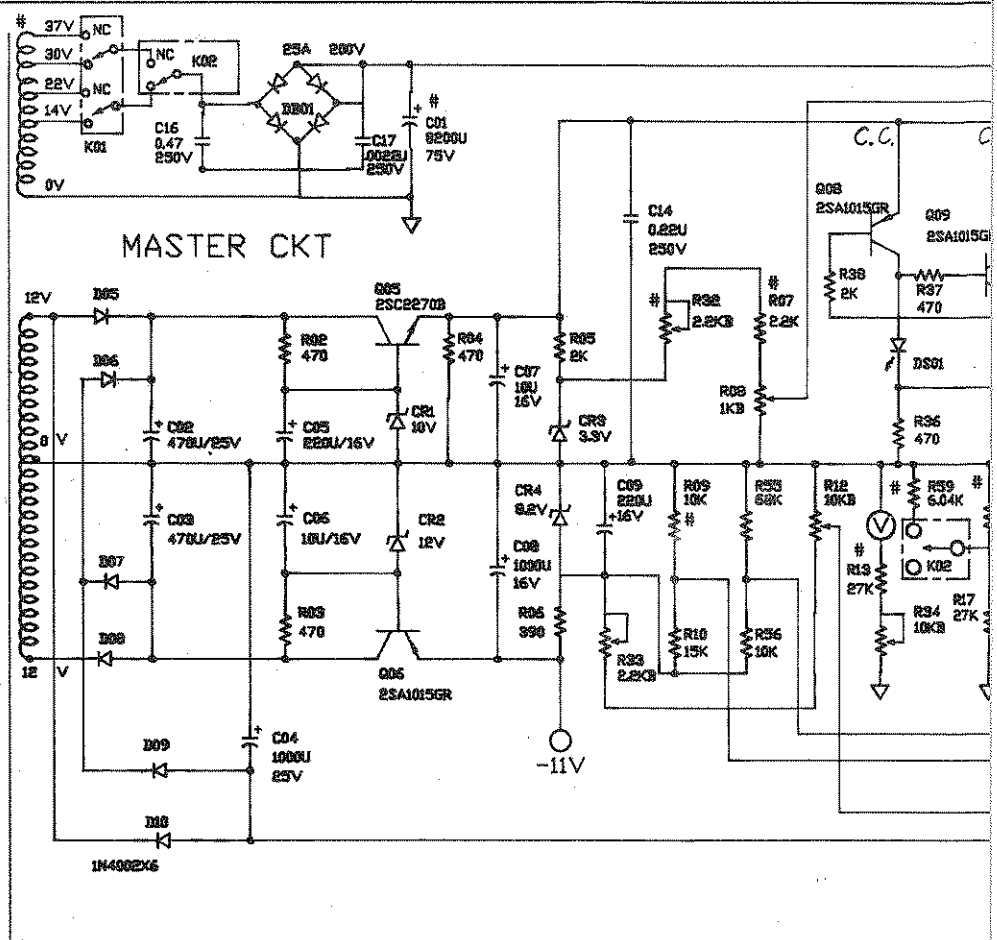
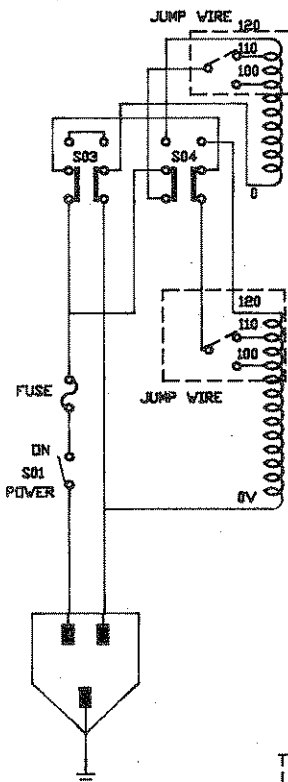

NOTE :
 1. SLAVE CKT IS SAME AS MASTER'S, EXCEPT 'S' MARKED, PLEASE SEE TABLE A FOR DETAILS.

TABLE A

#	MASTER	SLAVE
DSD3	ND	YES
R45	ND	YES

2. ALL RESISTORS VALUES ARE IN OHM UNLESS OTHERWISE SPECIFIED (K-KILOHM, M-MEGOHM)
3. ALL CAPACITORS VALUES ARE IN uF
4. ALL PARTS OF 4000S ARE THE SAME, EXCEPT THOSE MARKED WITH '#'. PLEASE SEE PARTS LIST FOR DETAILS

5 ↓ DENOTE OUTPUT-

SPECIFICATIONS

Mode		4302	4303	4306	4602	4603
Output	DC Voltage DC Current	0-30V 0-2A	0-30V 0-3A	0-30V 0-6A	0-60V 0-2A	0-60V 0-3A
Loading Effect (Load Regulation)	CV CC	0.02% + 5mV 0.02% + 5mA				
Source Effect (line Regulation)	CV CC	0.02% + 2mA 0.02% + 0.25mA				
PARD (Ripple & Noise) At Any Line Voltage	CV CC	0.5mV(rms), 4mV(p-p) 0.5mA(rms), 4mA(p-p)				
Input 110V/120V/220V/240V ± 10%		2.6A 290W 60Hz	3.7A 400W 60Hz	4.7A 539W 60Hz	4.3A 470W 60Hz	6.1A 680W 60Hz
Constant 5V Output Load and Source Effect Ripple and Noise < 2 mV		Voltage Range: 4.75V Min, 5.25V Max 0.1% + 5mV Output Current 3A ± 10% 4302 and 4303 only				
Dimensions: (Width, Height, Depth in mm)		250*140*363	250*140*363	250*140*423	250*140*423	250*140*423
Weight : (in KG)		9	10	14	13	13
Accessory : ACS-002 (Banana Clip)		2	2	2	2	2
Operating Temperature Range		0 C to 40 C in Operation -20C to 55 C in Storage				

Notes: CV=Constant Voltage, CC=Constant Current
Input voltage can be factory-modified to meet different country.

PARTS LIST -- LOW POWER SERIES

Most parts of TPS-4302,4303 are the same, except those marked with '#'. The following table specifies the difference between these models.

PART	MODEL	
	4302	4303
D001-004	1N5402	TIE 620
Q007	2N3055	2N3772
R007	5.1K	2.7K
R025	270	330
R032	3.3K	2.2K

Location Description

C 001	ELECTROLYTIC CAPACITOR 3300UF 75V +80%~-20%
C 002	ELECTROLYTIC CAPACITOR 470UF 25V +80-20%
C 003	ELECTROLYTIC CAPACITOR 470UF 25V +80-20%
C 004	ELECTROLYTIC CAPACITOR 470UF 25V +80-20%
C 005	ELECTROLYTIC CAPACITOR 220UF 16V +80%~-20%
C 006	ELECTROLYTIC CAPACITOR 10UF 16V +80%~-20%
C 007	ELECTROLYTIC CAPACITOR 10UF 16V +80%~-20%
C 008	ELECTROLYTIC CAPACITOR 1000UF 16V +80%~-20%
C 009	ELECTROLYTIC CAPACITOR 220UF 16V +80%~-20%
C 011	MYLAR CAPACITOR 0.22UF 50V 10% (L TYPE)
C 013	ELECTROLYTIC CAPACITOR 2.2UF 50V +80-20%
C 015	MYLAR CAPACITOR 0.22UF 50V 10% (L TYPE)
C 016	MYLAR CAPACITOR 0.47UF 100V 10%
C 023	MYLAR CAPACITOR 0.47UF 100V 10%
C 301	ELECTROLYTIC CAPACITOR 4700UF 16V +80%~-20% (AXIAL)
C 302	ELECTROLYTIC CAPACITOR 4700UF 16V +80%~-20% (AXIAL)
C 303	ELECTROLYTIC CAPACITOR 4.7UF 16V +80%~-20%
C 304	ELECTROLYTIC CAPACITOR 4.7UF 16V +80%~-20%
CR001	ZENER DIODE 10V 5% 0.5W
CR002	ZENER DIODE 12V 5% 0.5W
CR003	ZENER DIODE 3.3V 5% 0.5W
CR004	ZENER DIODE 8.2V 5% 0.5W
# D 001	DIODE D-620 6A 200V
# D 002	DIODE D-620 6A 200V
# D 003	DIODE D-620 6A 200V
# D 004	DIODE D-620 6A 200V
D 005	DIODE 1N4002 100V 1A
D 006	DIODE 1N4002 100V 1A
D 007	DIODE 1N4002 100V 1A
D 008	DIODE 1N4002 100V 1A
D 009	DIODE 1N4002 100V 1A
D 010	DIODE 1N4002 100V 1A
D 011	DIODE 1N4148 75V 100mA
D 012	DIODE 1N4002 100V 1A
D 013	DIODE 1N4002 100V 1A
D 014	DIODE 1N4002 100V 1A
D 302	DIODE 1N4002 100V 1A
DB302	DIODE BRIDGE 4A 50V
DS001	LED CS-0311-4 (RED) 5mm ROUND
DS002	LED CS-0311-4 (RED) 5mm ROUND
DS003	LED CS-0311-4 (RED) 5mm ROUND
DS301	LED CS-0311-4 (RED) 5mm ROUND
K 001	RELAY 12V 5A 2POLES EMI 6 PIN 250VAC
Q 001	TRANSISTOR 2SC1815 GR
Q 002	TRANSISTOR 2SC2270B OR 2SC2270C
Q 003	TRANSISTOR 2SC1815 GR
Q 004	TRANSISTOR 2SA1015 GR

Location Description

Q 005 TRANSISTOR 2SC2270B OR 2SC2270C
 Q 006 TRANSISTOR 2SA1015 GR
 # Q 007 TRANSISTOR 2N3772 TO-3 type
 Q 008 TRANSISTOR 2SA1015 GR
 Q 009 TRANSISTOR 2SA1015 GR
 Q 010 TRANSISTOR 2SA1015 GR
 Q 301 TRANSISTOR 2SA1015 GR
 Q 302 TRANSISTOR 2SA699
 R 002 CARBON FILM RESISTOR 470 1/4W 5%
 R 003 CARBON FILM RESISTOR 470 1/4W 5%
 R 004 CARBON FILM RESISTOR 470 1/4W 5%
 R 005 CARBON FILM RESISTOR 300 1/4W 5%
 R 006 CARBON FILM RESISTOR 390 1/4W 5%
 # R 007 CARBON FILM RESISTOR 2.7K 1/4W 5%
 R 008 VR 1KB D=24mm B-type WIRING-type NO TEETH SHAFTER=20R
 R 009 CARBON FILM RESISTOR 680K 1/4W 5%
 R 010 CARBON FILM RESISTOR 100K 1/4W 5%
 R 012 VR 10KB D=24mm B-type WIRING-type NO TEETH SHAFTER=20R
 R 013 CARBON FILM RESISTOR 27K 1/4W 5%
 R 014 CARBON FILM RESISTOR 470 1/4W 5%
 R 015 CARBON FILM RESISTOR 470 1/4W 5%
 R 016 CARBON FILM RESISTOR 270K 1/4W 5%
 R 017 CARBON FILM RESISTOR 300K 1/4W 5%
 R 018 CARBON FILM RESISTOR 100 1/4W 5%
 R 019 CARBON FILM RESISTOR 2.7K 1/4W 5%
 R 020 CARBON FILM RESISTOR 100 1/2W 5%
 R 021 CARBON FILM RESISTOR 100 1W 5%
 R 022 CARBON FILM RESISTOR 100 1/4W 5%
 R 023 WIRE WOUND RESISTOR 0.15 5% 5W (KNP TYPE)
 R 024 CARBON FILM RESISTOR 10K 1/4W 5%
 # R 025 CARBON FILM RESISTOR 330 1/4W 5%
 R 026 CARBON FILM RESISTOR 100 1/4W 5%
 R 027 CARBON FILM RESISTOR 10K 1/4W 5%
 R 028 CARBON FILM RESISTOR 4.7K 1/4W 5%
 R 029 CARBON FILM RESISTOR 15K 1/4W 5%
 R 030 METAL OXIDE FILM RESISTOR 3K 10% 5W
 # R 032 SVR 2.2KB CARBON FILM D=10mm (RIVER 10-C)
 R 033 SVR 2.2KB CARBON FILM D=10mm (RIVER 10-C)
 R 034 SVR 10KB CARBON FILM D=10mm (RIVER 10-C)
 R 035 SVR 220B CARBON FILM (RIVER 10-C)
 R 036 CARBON FILM RESISTOR 470 1/4W 5%
 R 037 CARBON FILM RESISTOR 470 1/4W 5%
 R 038 CARBON FILM RESISTOR 2K 1/4W 5%
 R 040 METAL FILM RESISTOR 10K 1/4W 0.25%
 R 045 CARBON FILM RESISTOR 1M 1/4W 5%
 R 301 METAL OXIDE FILM RESISTOR 51 2W 10%
 R 302 CARBON FILM RESISTOR 470 1/4W 5%

Location	Description
R 057	WIRE WOUND RESISTOR 0.15 5% 5W (KNP TYPE)
R 058	WIRE WOUND RESISTOR 0.15 5% 5W (KNP TYPE)
#R 059	METAL FILM RESISTOR 6.04K 1/4W 1%
S 001	TOGGLE SWITCH 3PIN 5A 125V (C&K 7101)
S 002	TOGGLE SWITCH 9 PIN 5A 125VAC
S 003	SLIDE SWITCH PCB-type 6PIN 5A 125V (ALPHA SS-13T-022-10)
S 004	SLIDE SWITCH PCB-type 6PIN 5A 125V (ALPHA SS-13T-022-10)
U 001	IC 741 OP-AMP
U 002	IC 741 OP-AMP
U 003	IC 741 OP-AMP
U 004	IC 741 OP-AMP

Location, Description

R 303	WIRE WOUND RESISTOR 0.2 5W 5%
S 001	TOGGLE SWITCH 3PIN 5A 125VAC
S 002	TOGGLE SWITCH 9 PIN 5A 125VAC
S 003	SLIDE SWITCH PCB-type 6PIN 5A 125V (ALPHA SS-13T-022-10)
S 004	SLIDE SWITCH PCB-type 6PIN 5A 125V (ALPHA SS-13T-022-10)
U 001	IC 741 OP-AMP
U 002	IC 741 OP-AMP
U 003	IC 741 OP-AMP
U 301	IC LM340T-5 5V 3% VOLTAGE REFRENCES

PARTS LIST -- HIGH POWER DUAL RELAY SERIES

Most parts of TPS-4306,4603,4602 are the same, except those marked with '#'. The following table specifies the difference between these models.

PART	MODEL		
	4306	4602	4603
C001	8200U/75V	4700U/100V	4700U/100V
R007	2.2K	5.1K	2.7K
R009	10K	68K	68K
R013	27K	56K	56K
R016	22K	27K	27K
R017	27K	38.3K	38.3K
R025	470	270	330
R029	15K	33K	33K
R030	3K/5W	5.6K/3W	5.6K/3W
R032	2.2K	3.3K	2.2K
R040	10K	44.9K	44.9K
R050	27K	15K	15K
R052	30K	47K	47K
R059	6.04K	8.2K	8.2K

Location Description

#	Location	Description
C 001		ELECTROLYTIC CAPACITOR 8200UF 75V +80%~-20%
C 002		ELECTROLYTIC CAPACITOR 470UF 25V +80-20%
C 003		ELECTROLYTIC CAPACITOR 470UF 25V +80-20%
C 004		ELECTROLYTIC CAPACITOR 1000UF 25V +80%~-20%
C 005		ELECTROLYTIC CAPACITOR 220UF 16V +80%~-20%
C 006		ELECTROLYTIC CAPACITOR 10UF 16V +80%~-20%
C 007		ELECTROLYTIC CAPACITOR 10UF 16V +80%~-20%
C 008		ELECTROLYTIC CAPACITOR 1000UF 16V +80%~-20%
C 009		ELECTROLYTIC CAPACITOR 220UF 16V +80%~-20%
C 010		MYLAR CAPACITOR 0.22UF 250V 10%
C 011		MYLAR CAPACITOR 0.22UF 250V 10%
C 012		ELECTROLYTIC CAPACITOR 100UF 100V +80%~-20%
C 013		ELECTROLYTIC CAPACITOR 2.2UF 100V +80% ~ -20%
C 014		MYLAR CAPACITOR 0.22UF 250V 10%
C 016		MYLAR CAPACITOR .47UF 250V 10% (MD TYPE)
C 017		MYLAR CAPACITOR 0.0022UF 250V 10%
C 023		MYLAR CAPACITOR .47UF 250V 10% (MD TYPE)
CR001		ZENER DIODE 10V 5% 0.5W
CR002		ZENER DIODE 12V 5% 0.5W
CR003		ZENER DIODE 3.3V 5% 0.5W
CR004		ZENER DIODE 8.2V 5% 0.5W
D 005		DIODE 1N4002 100V 1A
D 006		DIODE 1N4002 100V 1A
D 007		DIODE 1N4002 100V 1A
D 008		DIODE 1N4002 100V 1A
D 009		DIODE 1N4002 100V 1A
D 010		DIODE 1N4002 100V 1A
D 011		DIODE 1N4148 75V 100mA
D 012		DIODE 1N4002 100V 1A
D 013		DIODE 1N4002 100V 1A
D 014		DIODE 1N4002 100V 1A
D 015		DIODE 1N4002 100V 1A
DB001		DIODE BRIDGE 25A 200V
DS001		LED CS-0311-4 (RED) 5mm ROUND
DS002		LED CS-0311-4 (RED) 5mm ROUND
DS003		LED CS-0311-4 (RED) 5mm ROUND
K 001		RELAY 12V 160OHM 2POLES SRET 10A (SRET-202 DP5)
K 002		RELAY 12V 160OHM 2POLES SRET 10A (SRET-202 DP5)
Q 001		TRANSISTOR 2SC1815 GR
Q 002		TRANSISTOR 2SC2270B OR 2SC2270C
Q 003		TRANSISTOR 2SC1815 GR
Q 004		TRANSISTOR 2SA1015 GR
Q 005		TRANSISTOR 2SC2270B OR 2SC2270C
Q 006		TRANSISTOR 2SA1015 GR
Q 007		TRANSISTOR 2SD873
Q 008		TRANSISTOR 2SA1015 GR
Q 009		TRANSISTOR 2SA1015 GR

Location Description

Q 010 TRANSISTOR 2SA1015 GR
 Q 011 TRANSISTOR 2SA1015 GR
 Q 012 TRANSISTOR 2SD873
 R 002 CARBON FILM RESISTOR 470 1/4W 5%
 R 003 CARBON FILM RESISTOR 470 1/4W 5%
 R 004 CARBON FILM RESISTOR 470 1/4W 5%
 R 005 CARBON FILM RESISTOR 2K 1/4W 5%
 R 006 CARBON FILM RESISTOR 390 1/4W 5%
 # R 007 CARBON FILM RESISTOR 2.2K 1/4W 5%
 R 008 VR 1KB D=24mm B-type WIRING-type NO TEETH SHAFTER=20R
 # R 009 CARBON FILM RESISTOR 10K 1/4W 5%
 R 010 CARBON FILM RESISTOR 15K 1/4W 5%
 R 012 VR 10KB D=24mm B-type WIRING-type NO TEETH SHAFTER=20R
 # R 013 CARBON FILM RESISTOR 27K 1/4W 5%
 R 014 CARBON FILM RESISTOR 470 1/4W 5%
 R 015 CARBON FILM RESISTOR 470 1/4W 5%
 # R 016 CARBON FILM RESISTOR 22K 1/4W 5%
 # R 017 CARBON FILM RESISTOR 27K 1/4W 5%
 R 018 CARBON FILM RESISTOR 100 1/4W 5%
 R 019 CARBON FILM RESISTOR 2.7K 1/4W 5%
 R 020 CARBON FILM RESISTOR 100 1/2W 5%
 R 021 CARBON FILM RESISTOR 100 1W 5%
 R 022 CARBON FILM RESISTOR 100 1/4W 5%
 R 023 WIRE WOUND RESISTOR 0.15 5% 5W (KNP TYPE)
 R 024 CARBON FILM RESISTOR 10K 1/4W 5%
 # R 025 CARBON FILM RESISTOR 470 1/4W 5%
 R 026 CARBON FILM RESISTOR 100 1/4W 5%
 R 027 CARBON FILM RESISTOR 10K 1/4W 5%
 R 028 CARBON FILM RESISTOR 4.7K 1/4W 5%
 # R 029 CARBON FILM RESISTOR 15K 1/4W 5%
 # R 030 METAL OXIDE FILM RESISTOR 3K 3W 10%
 R 031 WIRE WOUND RESISTOR 0.15 5% 5W (KNP TYPE)
 # R 032 SVR 2.2KB CARBON FILM D=10mm (RIVER 10-C)
 R 033 SVR 2.2KB CARBON FILM D=10mm (RIVER 10-C)
 R 034 SVR 10KB CARBON FILM D=10mm (RIVER 10-C)
 R 035 SVR 220B CARBON FILM (RIVER 10-C)
 R 036 CARBON FILM RESISTOR 470 1/4W 5%
 R 037 CARBON FILM RESISTOR 470 1/4W 5%
 R 038 CARBON FILM RESISTOR 2K 1/4W 5%
 # R 040 METAL FILM RESISTOR 10K 1/4W 0.25%
 R 045 CARBON FILM RESISTOR 1M 1/4W 5%
 # R 050 CARBON FILM RESISTOR 27K 1/4W 5%
 # R 052 CARBON FILM RESISTOR 30K 1/4W 5%
 R 053 CARBON FILM RESISTOR 100 1W 5%
 R 054 CARBON FILM RESISTOR 2.7K 1/4W 5%
 R 055 CARBON FILM RESISTOR 68K 1/4W 5%
 R 056 CARBON FILM RESISTOR 10K 1/4W 5%